

TP-P401 | MULTI LANE SACHET MACHINE FOR POWDERY PRODUCTS

TURPACK
www.turpack.com



This fully automatic packaging machine that is designed to prepare 4 side sealed sachet-type packages, and to place untouched non free flowing powdered products. Cream, coffee, mix flour, powdered beverages, black pepper, powder, cinnamon, soups, yeast, milk powder and similar products that have no self fluidity can be packed with a servo motor driven dosing system to assure precise weights in each packet. The machine can produce 60 pcs/min using 2 channels and 240 pieces with 8 channels.

Technical Specifications

Number Of Lanes	1-10 Lanes Sachet (Depending on Width)
Filling Weight Range	(0,25-1 gr) (1-5 gr) (5-20 gr) (20-50 gr)
Bag Width	Between 40mm to 120mm (Depending on the Max Roll Width)
Bag Length	Max 150 mm (adjustable)
Capacity	30-35 Sachets/min/Lane (Max 350 pcs/min)
Filling System	Sachets Auger Dosing
Servo Motor	KOLLMORGEN
Control System	SIEMENS PLC
Pneumatic System	FESTO
Sensor	SICK
Construction Body	SS304
Parts In Product Contact	SS316
Package Style Format	4 Side Seal Sachet
Maximum Roll Width	800 mm Max.
Maximum Roll Diameter	450 mm Max.
Compressed Air Cons.	6 Bar, (MAX 450 Litres/min)
Weigth of the Machine	875 kg
Electricity Connection	Can be produced according to your country's connection system.
Power Consumption	11 KW
Package Specification	12 PET, 7 AL, 35-60 PE
Application	Non Free Flowing Products: coffee, gold coffee, 3in1, coffee cream, powdery chemicals, etc.
Optional Features	Date Coding System Additional Servo Motor Conveyor Belt Notch For Sachet Machine Guillotine Notch For Sachet Machine Perforation Auto Feeding System

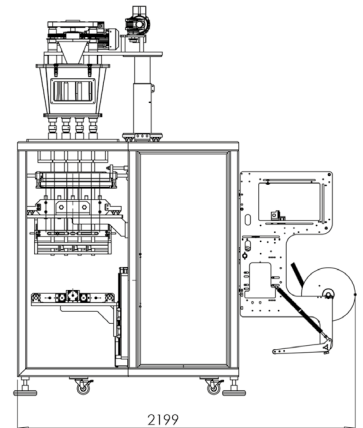
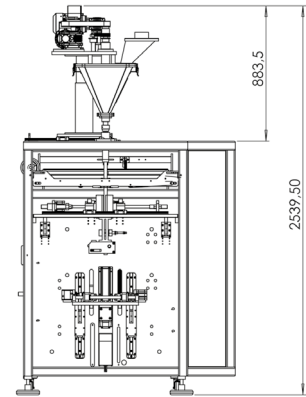

SUITABLE FOR

Packing non free flowing products, such as coffee cream, instant soup, lemon powder, instant drink powder, flour, powdery chemicals, medical powders etc.



Dimensions, weight, power usage and technical drawings are for the machine in the picture. There may be slight variations for different machines.